

Optical Encoders

Incremental Encoder Type E50

Block diagram

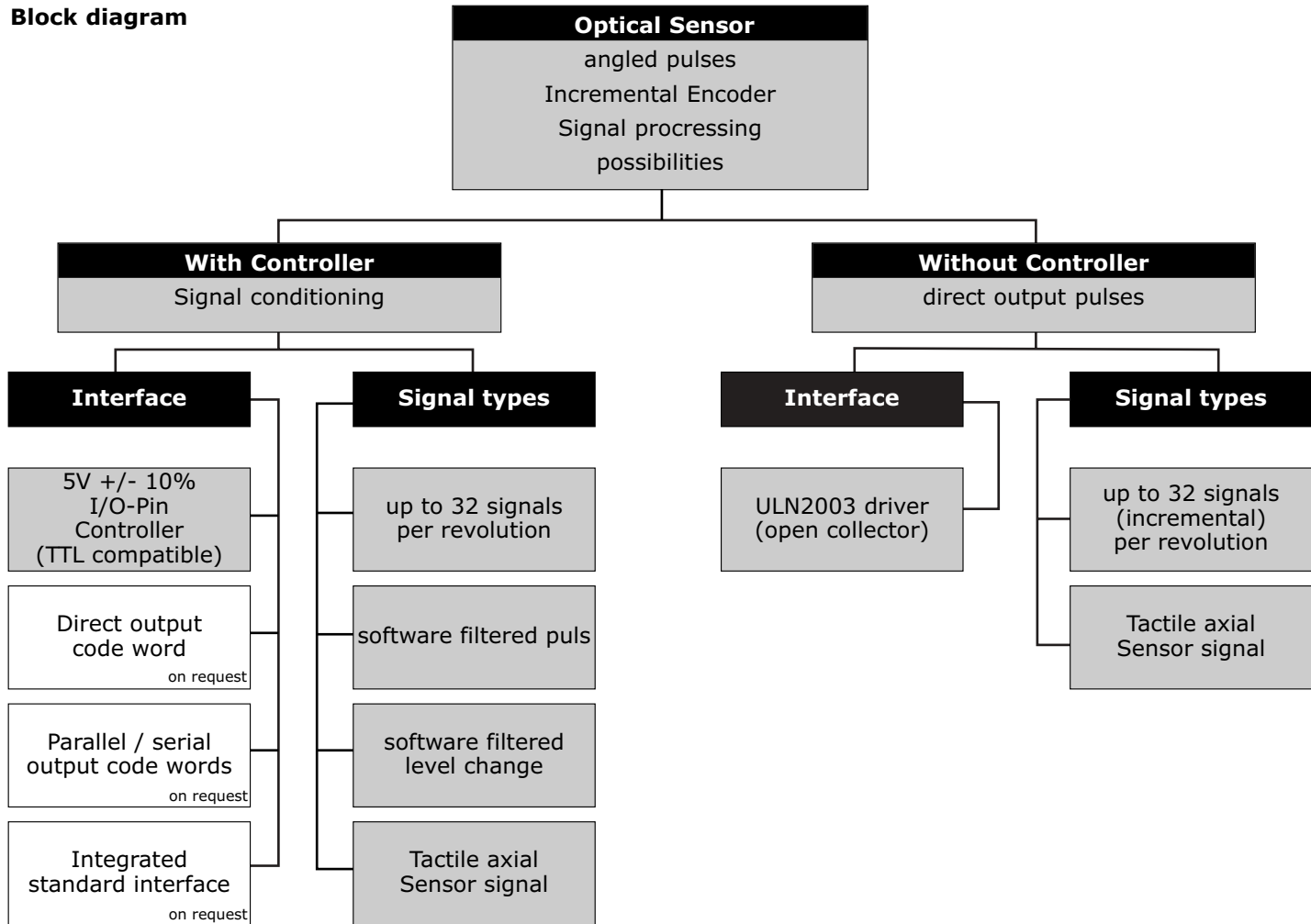

Functions diagram

With Controller

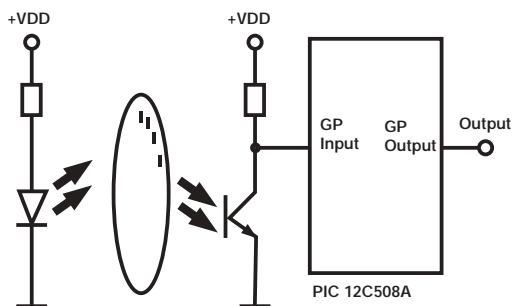

Without Controller

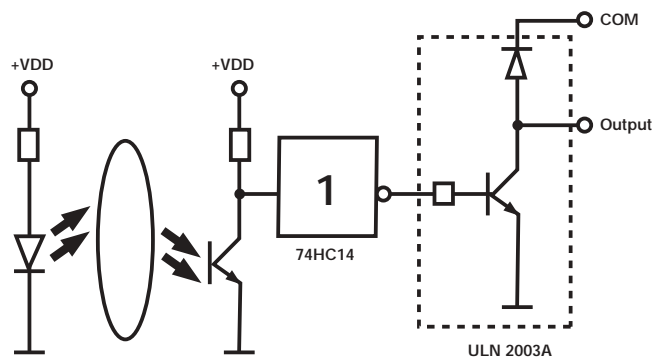

1 mm = 0.04 inch

1 inch = 25.4 mm

Optical Encoders

Incremental Encoder Type E50

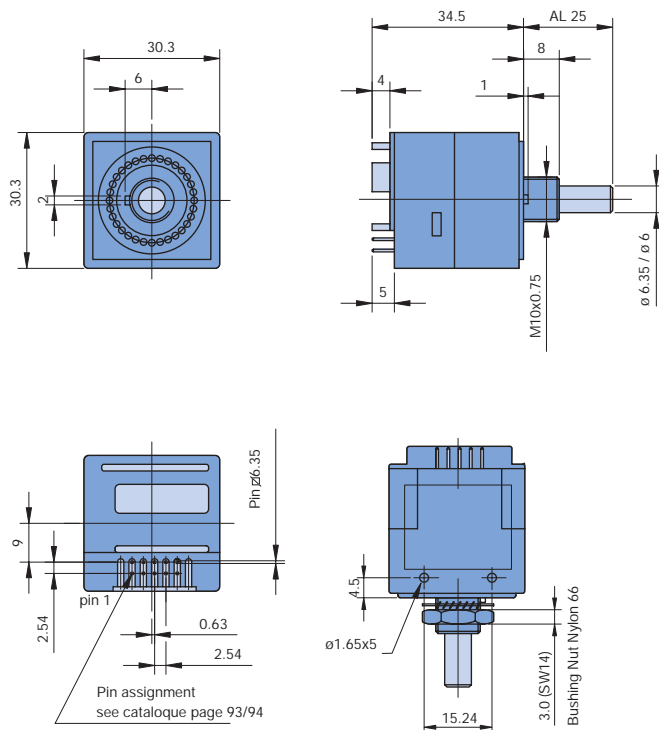

Description

When designing this rotary encoder the latest technology has been used. It is designed as a pulse signal output device that features a long life, inexpensive and very reliable.

The signal generation for both the rotary encoder and push-button function is an optoelectronic contactless binary sensor. Magnetic fields will provide a contactless / long life indexing system.

The modular construction allows a variety of mechanical and electrical configurations.

Mechanical data

Maximum tightening torque of central fastening:
0,4 Nm

Indexing torque:
24 detend: 0,45 Ncm or 1,5 Ncm +/-50%
32 detend: 0,6 Ncm or 1,3 Ncm +/-50%

Actuating force of axial button
5 N

Maximum actuating force of axial button: 50 N

Maximum speed: 600 rotations/min

Maximum load on the axle for continuous operation:
Axial: plastic shaft 2 N,
Radial: plastic shaft 3 N,

Life time:
Axial button > 5 x 10⁶ actuation
Rotary encoder with indexing > 10 x 10⁶ rotations

Housing material
high quality thermoplastic

Electrical data

Output signal
Encoder: incremental
Push button: pulse

Encoder
24 position:
24 pulses / channel / 360°
32 position:
32 pulses / channel / 360°

Limit values
Storage temperature
-20 °C to 80 °C
Supply voltage V_{dd}: 0 to 7V
Max. output current: 20mA

Operating conditions
Temperature range: -20 °C to +70 °C
Supply voltage V_{dd}: 5V +/- 10% (Version with voltage regulator: 5V to 26V).

Max. supply current without load
max. 40mA at V_{dd}

Electrical connection
Terminal strip, straight on request
Cable with connector.

Soldering
Hand: <5s < 260°C

Optical Encoders

Incremental Encoder Type E50

General

E50 incremental rotary encoders generate in-quadrature pulses when the shaft rotates and a separate change in signal for the duration of any axial motion. Various control algorithms can be implemented to evaluate these signals.

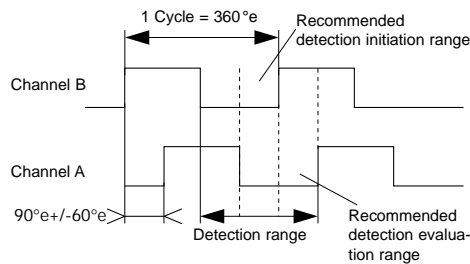

Timing diagram:

- Signal A is nominally in quadrature to signal B (phase angle 90°e)
- 360°e = 360°/number of indexing or signals per rotation (24 or 32)
- A = B = High is the indexed position and is outside the detection range because of magnetic indexing.
- The signals should not be evaluated until the state A = B = Low is reached.
- In addition to this, High is output for the duration of any axial motion acting on the shaft (output transistor blocked).

Incremental Encoder without controller

Limit values

Output driver : ULN 2003A
 Output voltage range U_{ce} :
 -0 to +50V
 Supply voltage V_{dd} :-0,7 to 7V
 Max. power dissipation: 1 W
 Max. current on each I/O: 200 mA
 Storage temperature: -25° to +80 °C

Operating values

Collector reverse current
 500 μ A at 70 °C
 Operating temperature
 -20° to +70 °C

External wiring

As driver an ULN2003A with open collector output with integrated clamp diodes is used. The cathode of all clamp diodes is connected to common and protects the encoder against, for instance, inductive surges. For this purpose, the common pin must be connected to U_{ce} to which the pull-up or load resistors are also connected.

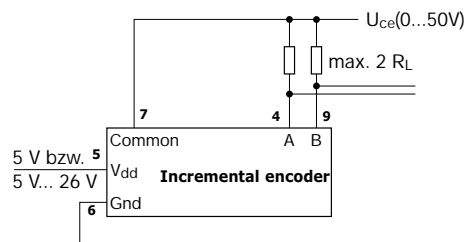

5V operating voltage

Direct output of in-quadrature signals and axial signal via drivers:
 Supply voltage V_{dd} 5V +/- 10%
 Supply current (typical) 35 mA at 5 V

Pin assignment

Pin	Assignment	Pin	Assignment
1	no connection	2	no connection
3	no connection	4	Channel A
5	V_{dd}	6	Ground
7	Common (clamp diodes)	8	no connection
9	Channel B	10	Axial signal

Plug assignment, bottom view:

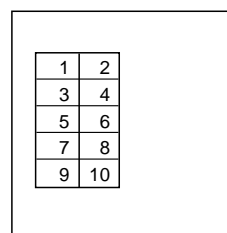

5-26V operating voltage

Direct output of in-quadrature signals and axial signal via drivers:
 Supply voltage V_{dd} 5 to 26V
 Supply current (typical) 40 mA

Pin assignment

Pin	Assignment	Pin	Assignment
1	no connection	2	no connection
3	no connection	4	Channel A
5	V_{dd}	6	Ground
7	Common (clamp diodes)	8	no connection
9	Channel B	10	Axial signal

Plug assignment, bottom view:

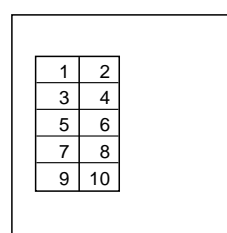

Optical Encoders

Incremental Encoder Type E50

Incremental Encoders with controller

Limit values

Operating voltage range
U_{dd} - 0,7 to +7 V

Output controller: PIC12C508A
Max. current into V_{dd} pin: 50 mA
Max. current on each I/O: 20 mA
Storage temperature
-25° to +80 °C

Operating values

Operating voltage: 5V +/- 10%
Typical power input:
20 to 35 mA
Operating temperature:
-20° to + 70 °C

5V operating voltage, software filtered level change

Our detent mechanism is provided via a system of magnets. By using a low switching torque (<1 Ncm) "magnet hunting" for position occurs and provides incident signals. In the electronic of the E50, these incident signals are filtered out by the integrated software.

Pin	Signal	Signal description
1	no connection	
2	no connection	
3	Turn direction D	Turning clockwise: Low Turning counter-clockwise: High will be activated approx. 2 μs before clock pulse C
4	no connection	
5	V _{dd}	supply voltage: 5V +/- 10%
6	Gnd	Ground
7	no connection	
8	Clock pulse C	Level change between every indexing step
9	no connection	
10	Push-button	Change on Low at pushing the shaft

Plug assignment, bottom view:

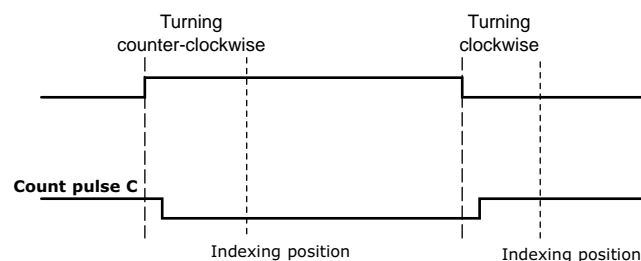
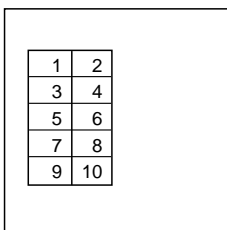

5V operating voltage, software filtered pulse

Our detent mechanism is provided via a system of magnets. By using a low switching torque (<1 Ncm) "magnet hunting" occurs and provides incident signals. In the electronic of the E50, these incident signals are filtered out by the integrated software.

1	no connection	
2	no connection	
3	no connection	
4	Channel A	Incremental output A, software filtered Output together with channel B during every rotary movement
5	V _{dd}	supply voltage: 5V +/- 10%
6	Gnd	Ground
7	no connection	
8	no connection	
9	Channel B	Incremental output B, software filtered Output together with channel A during every rotary movement
10	Push-button	Change on Low at pushing the shaft

Plug assignment, bottom view:

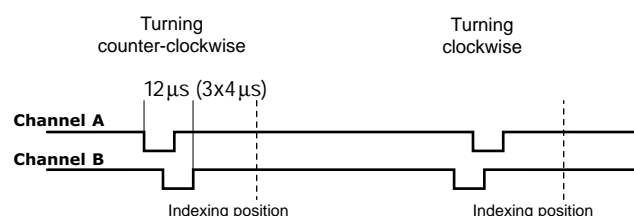
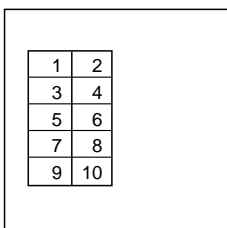

Ordering code Type E50

E 5 0 - X X X X - X X X X

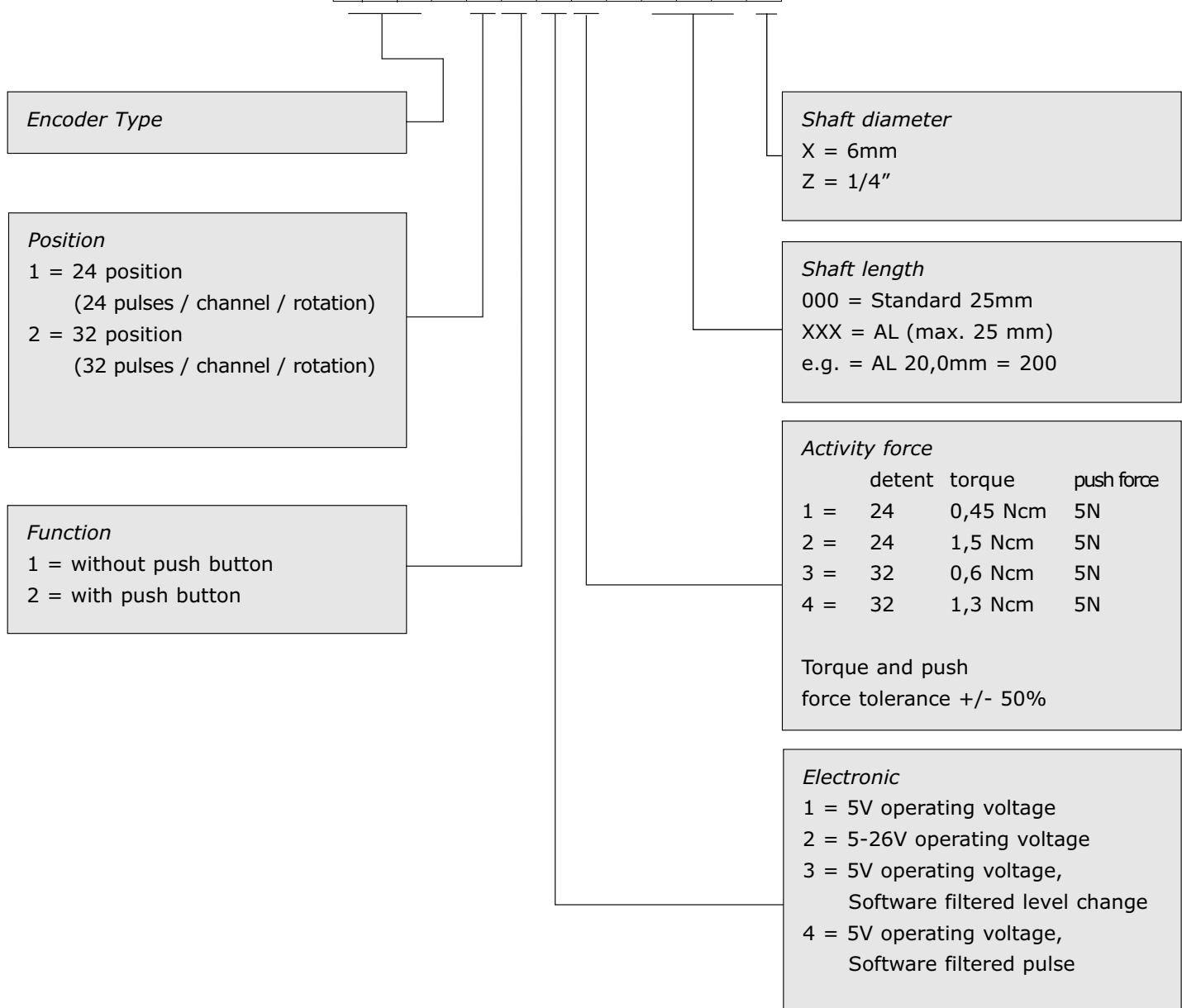

Electronic options

	Axial-signal	Direct signal output	Software filtered pulse	Software filtered level change	Open collector output	Voltage Regulator
5V operating voltage	●	●			●	
5-26V operating voltage	●				●	●
5V operating voltage, Software filtered level change	●			●		
5V operating voltage, Software filtered pulses	●		●			