

Pushbutton Switches with illumination



Specifications:

Contact rating:	250 V AC, 3 A / 125 V AC, 3 A 30 V DC, 3 A
Contact resistance:	< 50 mΩ
Insulation resistance:	> 100 MΩ at 500 V DC
Dielectric strength:	1500 V, 50 Hz for the duration of 1 minute
Operating temperature:	- 25° to + 70° C
Mechanical life:	minimum 30 000 operations
Contacts/Terminals:	solder tags or PC terminals, brass, silver-plated also available gold-plated, version B (see page 4)
Case material:	PA, black
Mounting:	single-hole mounting or on pc-board
Soldering conditions:	hand-soldering – max.: 30 W, 5 sec, 270° C auto-soldering – max.: 3 sec, 245° C ± 10° C

3

Models: Switching functions

D P D T

LP 2 SR. – PC	on – mom
LP 2 SN. – PC	on – on

Illumination by one LED

- R (LED red)
- G (LED green)
- Y (LED yellow)

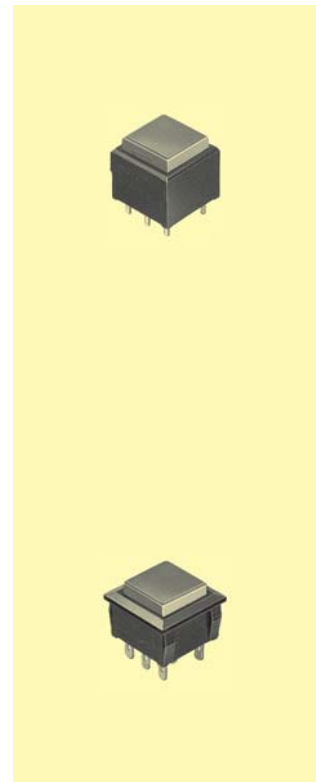
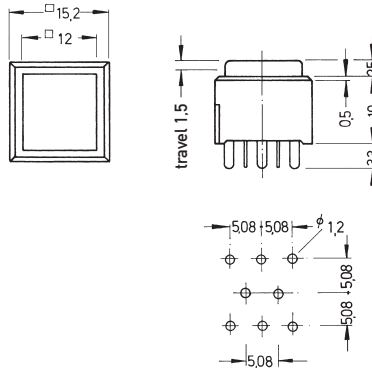

D P D T

LP 2 SR.	on – mom
LP 2 SN.	on – on

Illumination by one LED

- R (LED red)
- G (LED green)
- Y (LED yellow)

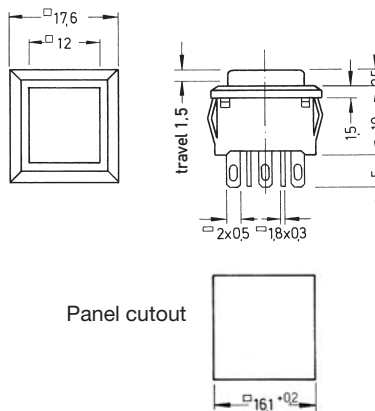



Pushbutton Switches with illumination

Models: Switching functions

D P D T

LP 2 WR. – PC on – mom

LP 2 WN. – PC on – on

Illumination by two LEDs

R (LED red)

G (LED green)

Y (LED yellow)

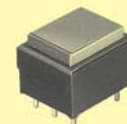
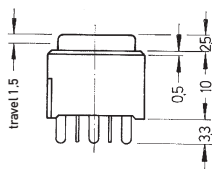
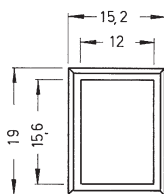

LP 2 WR RG – PC on – mom

LP 2 WN RG – PC on – on

Illuminated split lens

in red and green with one LED each

(further combinations on request)

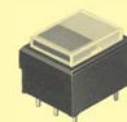
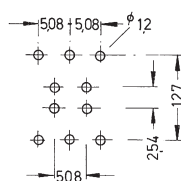
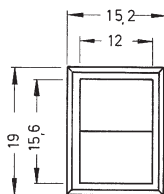

D P D T

LP 2 WR. on – mom

LP 2 WN. on – on

Illumination by two LEDs

R (LED red)

G (LED green)

Y (LED yellow)

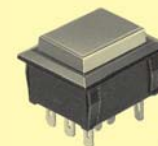
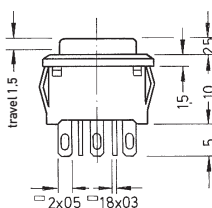
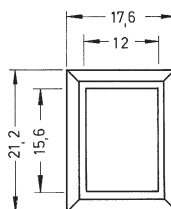

LP 2 WR RG on – mom

LP 2 WN RG on – on

Illuminated split lens

in red and green with one LED each

(further combinations on request)

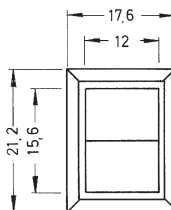

Panel cutout

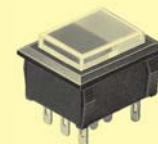
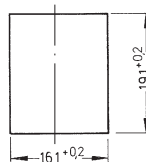

LP 2 .. R: I_F = 30 mA; U_F = 2,0 V

LP 2 .. G: I_F = 20 mA; U_F = 1,95 V

LP 2 .. Y: I_F = 20 mA; U_F = 1,9 V

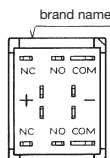
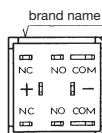

Illuminated Tact Switches for SMT



Specifications:

Contact rating:	12 V DC, 50 mA
Contact resistance:	100 mΩ max.
Insulation resistance:	100 MΩ min.
Dielectric strength:	250 V AC (50–60 Hz) for 1 minute
Operating temperature:	– 20° to + 70° C
Operating force:	1,6 N + 0,8/–0,3 N
Mechanical life:	50 000 cycles
Stem/cover:	high-temp. PA 9T UL 94 V–0, white
Terminal:	brass, silver-plated
Contact:	stainless steel, silver-plated
Base:	high-temp. PA 9T UL 94 V–0, molded black

3

Models:

TSSL 3W □ □

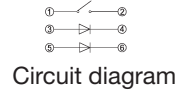
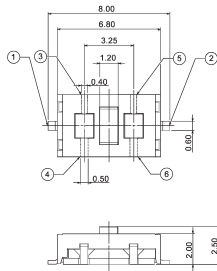
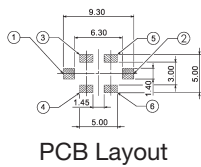

TSSL 3W □ □

- Left LED:**
- Ⓡ red
 - ⓐ green
 - Ⓞ soft orange
 - Ⓦ white
 - ⓑ blue

- Right LED:**
- Ⓡ red
 - ⓐ green
 - Ⓞ soft orange
 - Ⓦ white
 - ⓑ blue

Soldering conditions (reflow soldering)

